

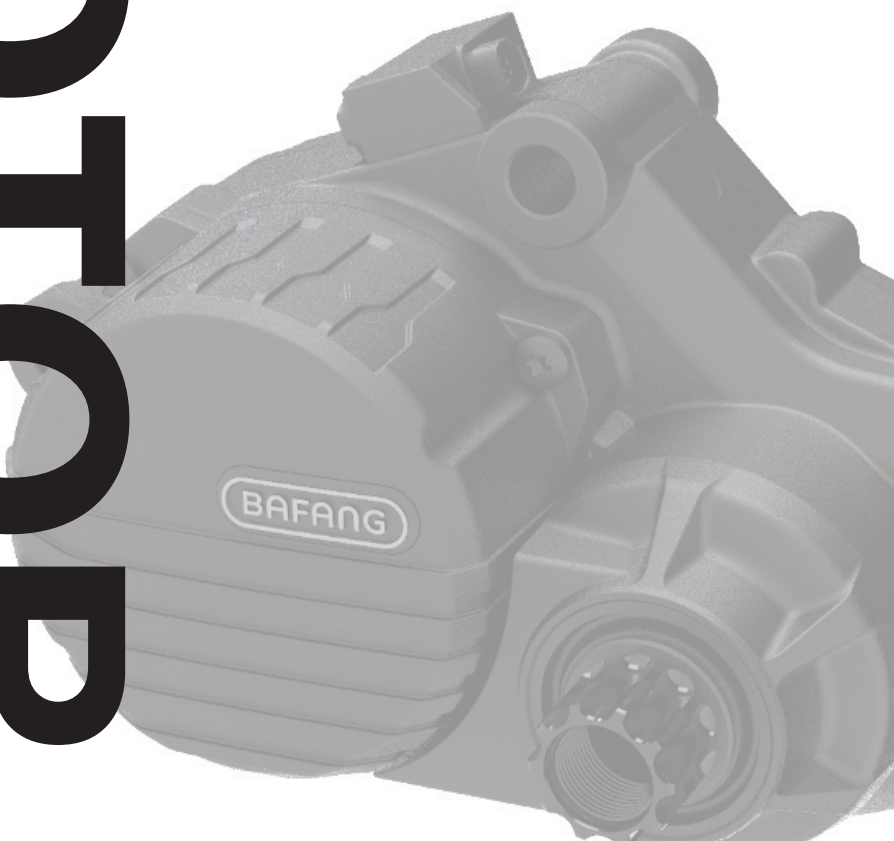

# MOTOR



# 6 DEALER MANUAL FOR M820 (MM G532.250.C)

---



## CONTENT

---

<b>6.1 Introduction</b> .....	<b>2</b>	6.3.2 Cabling.....	5
<b>6.2 Specifications</b> .....	<b>3</b>	6.3.3 Motor Installation.....	6
6.2.1 Outline and Geometric Size.....	3	6.3.4 Drive Unit Cover Installation.....	6
6.2.2 Surface.....	4	6.3.5 Chain Wheel Installation.....	7
6.2.3 Storage Information.....	4	6.3.6 Crank Installation.....	7
<b>6.3 Drive Unit Installation</b> .....	<b>5</b>	6.3.7 External Speed Sensor Installation.....	8
6.3.1 List of Tools to be Used.....	5	<b>6.4 Maintenance</b> .....	<b>9</b>

# 6.1 INTRODUCTION

---



- **Product Model**

MM G532.250.C

- **Scope**



Applies only to electrically powered bicycles, and specifically designed or licensed for Pedelec. It is suitable for road bikes on city roads, cement and asphalt roads and travel bikes on gravel roads. It should not be used commercial purposes.

- **Identification**

The following graphic, is the identification numbers of the product, which are shown on the housing:

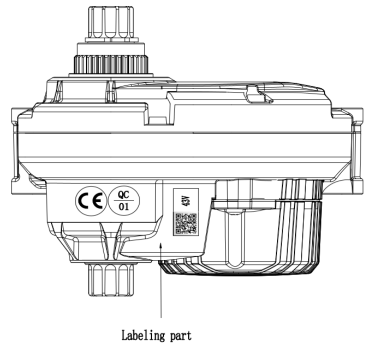

**Note:** Content in the label is important information about this product. Please do not remove the information from the motor.

## 6.2 SPECIFICATIONS

Motor model: MM G532.250.C

Rated power (W)	250
Rated voltage (V)	43
Waterproof	IP65
Certification	EMC / ISO13849
Outdoor Temperatures	-20 °C ~ 45 °C

### 6.2.1 Outline and Geometric Size

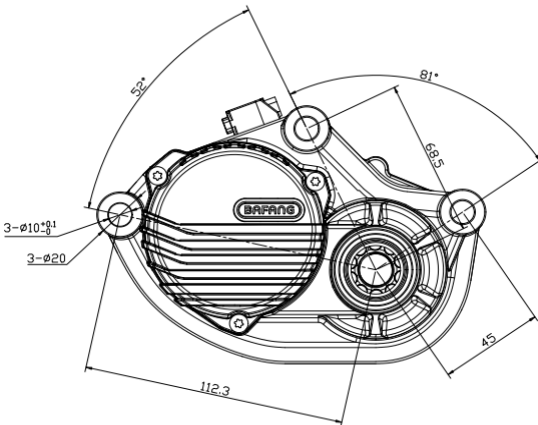

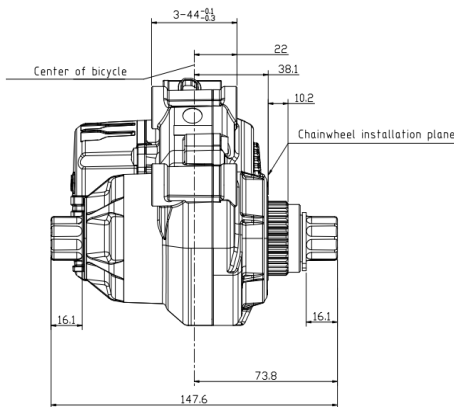
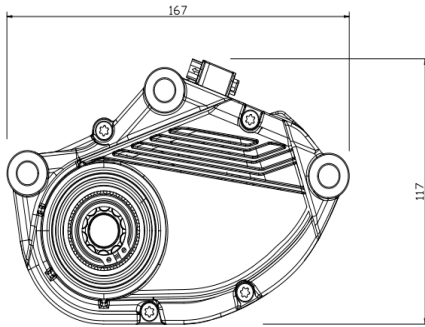

## 6.2.2 Surface







Shockproof black coating

## 6.2.3 Storage Information

The pedelec should be stored in a ventilated dry room. Avoid storing the pedelec near strong magnetic objects.

## 6.3 DRIVE UNIT INSTALLATION

### 6.3.1 List of Tools to be Used

Use of the Tools	Tools
To tighten/loosen bolts onto the frame interface and the drive unit	 Internal hex wrench
To tighten/loosen nuts onto the frame interface and the drive unit	 Socket spanner
To tighten/loosen M15 waterproof screws on the crank	 Internal hex wrench
To tighten/loosen lock-nut on chain wheel	 BAFANG Tool
To tighten/loosen screws on the speed sensor	 Cross screwdriver
	 Star screwdriver

### 6.3.2 Cabling

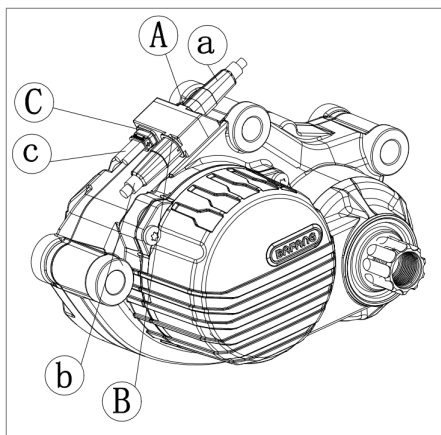

- A** Female 8 pin connector at the drive unit
- a** Male 8 pin connector from EB-BUS to speed sensor
- B** Male 8 pin connector at the drive unit
- b** Female 8 pin connector from EB-BUS
- C** Male connector for power supply at the drive unit
- c** Female connector for power supply at the battery

### 6.3.3 Motor Installation

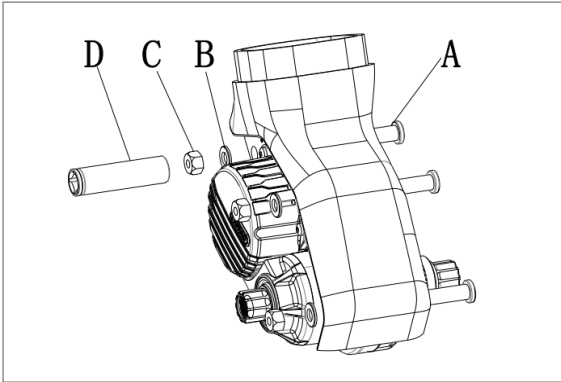

- A M8 bolts
- B M8 Flat washer
- C M8 Lock nuts
- D Standard tool

- 1) Align the three mounting holes of the drive unit with the mounting holes in the bike frame. From the right of the bike frame insert three M8 bolts into the mounting holes in the bike frame and the drive unit.
- 2) From the left, use standard tool tighten the three M8 Lock nuts with flat washer on the bike frame. Tightening torque requirement: 35 N.m.

### 6.3.4 Drive Unit Cover Installation

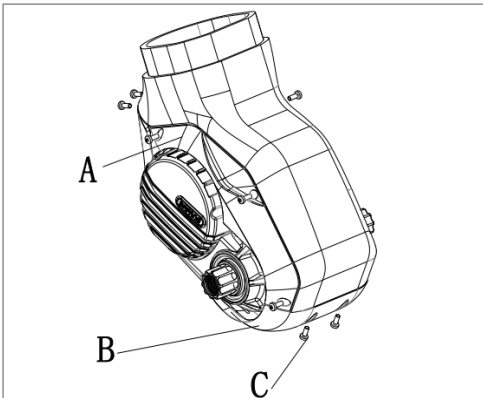

- A Left cover
- B Right cover
- C M3\*8 star pan head screws

Use a screwdriver (T10) and with three M3\*8 star pan head screws to fasten the motor cover and the interface together, the tightening torque requirement is 0.9-1.0 N.m.

### 6.3.5 Chain Wheel Installation

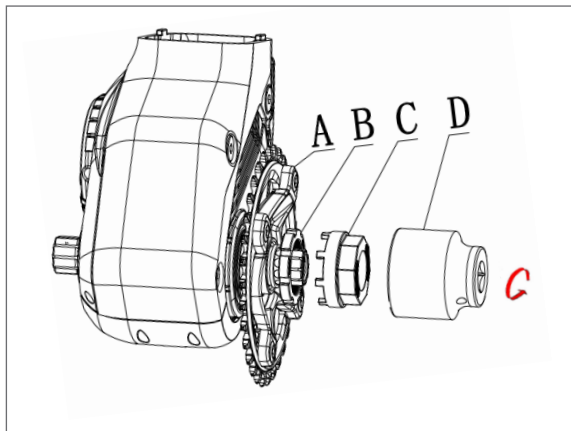

- A Chain wheel
- B Lock ring
- C BAFANG's tool
- D Standard tool

Put the chain wheel onto the spline shaft of the drive unit. Use BAFANG's tool to fasten the lock ring counterclockwise onto the spline shaft. Torque requirement: 35 N.m.

### 6.3.6 Crank Installation

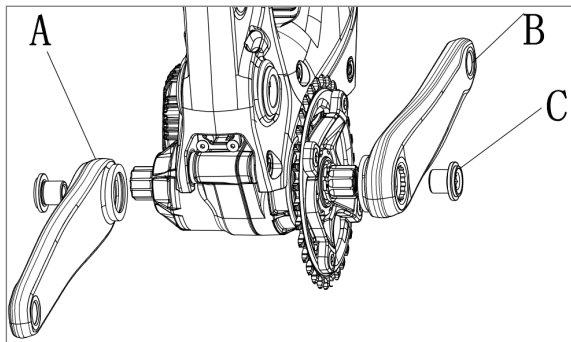

- A Left crank
- B Right crank
- C M15 waterproof screws

Mount right crank on the right shaft, with internal hex wrench fasten the M15 screws on the shaft (tightening torque is 45-50 N.m). Same way will left crank mount on the shaft (Note: Please guarantee the left and right crank parallel).



### 6.3.7 External Speed Sensor Installation

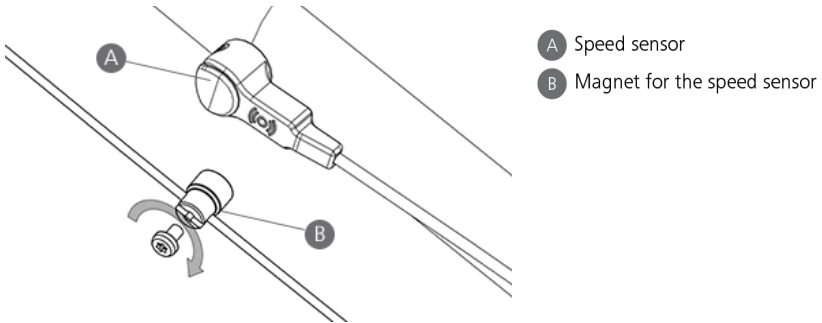

Fasten the mounting screws through the speed sensor and with a cross screwdriver. Tightening the speed sensor onto the frame. Torque requirement: 1.5-2 N.m. (Note: Please make sure the gap between the speed sensor and the magnetic unit is between 10 and 20 mm.)

Now place the magnet on the spoke of the wheel ensuring it is aligned to the middle of the speed sensor. And with a star key tighten the magnet in place. Torque requirement: 1.5-2 N.m.

## 6.4 MAINTENANCE

---

- Maintenance must be carried out by authorized personnel with the correct equipment.
- Do not disassemble the motor.
- Do not use thinners or other solvents to clean the components. Such substances can damage the surfaces.
- Avoid water submerging, to keep the components protected.
- Avoid using high-pressure cleaning jets.
- For prolonged storage, turn off the battery and avoid storing near heat sources.



MOTOR